

FIG.01 CYLINDER.CYLINDER HEAD 汽缸.汽缸頭

BMI  
MODEL:AAM-250E

NO	PARTS NO.	PARTS NAME	Q'TY
1	11111-CBT-00	CYLINDER COMP	1
2	11121-CBT-00	HEAD COMP, CYLINDER	1
3	11141-CBT-00	COVER, CYLINDER HEAD	1
4	11144-CBT-00	AIR SEAL HEAD SIDE COVER	2
5	11151-CBT-00	GASKET, CYLINDER	1
6	11181-CBT-00	GASKET, CYLINDER HEAD	1
7	11191-CBT-00	GASKET, HEAD COVER	1
8	11196-CBT-00	RING SEAD HEAD COVER	6
9	62210-GAT-00	PLUG, SPEAK (CR7HS NGK)	2
10	94410-10016	PIN, DOWEL 10*16	2
11	94706-06032-R	LINKED SCREW, AIR SEAL HEAD COVER	4
12	94706-06040-R	AIR SEAL HAED COVER	2
13	94717-08042-C	BOLT, STUD 8*42	4
14	95201-061005-B	NUT, HEXAGON	1
15	96414-06065-R	BOLT, FLANGE 6*65	1
16	96414-06145-B	BOLT, FLANGE 6*145	2

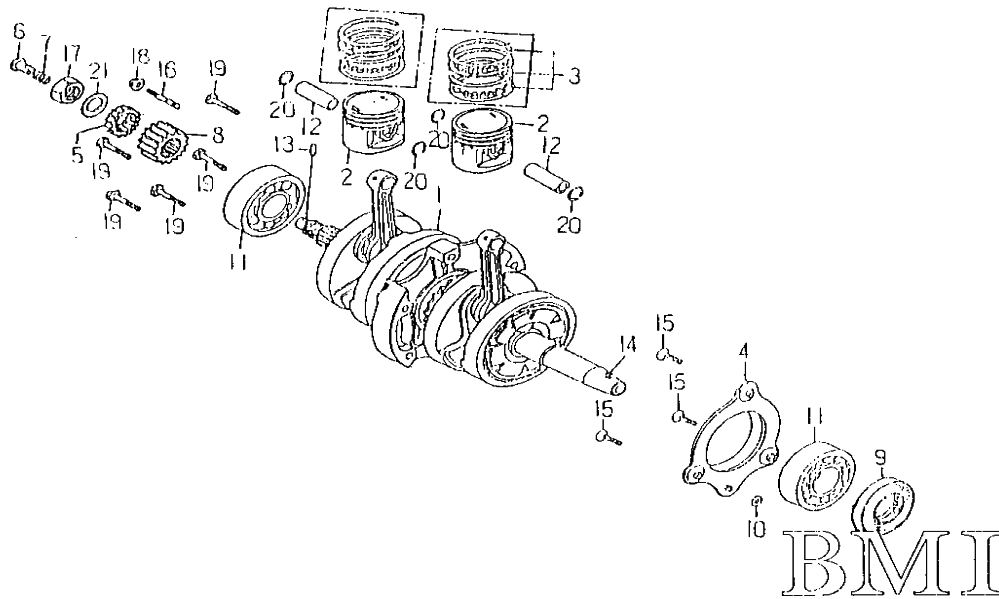
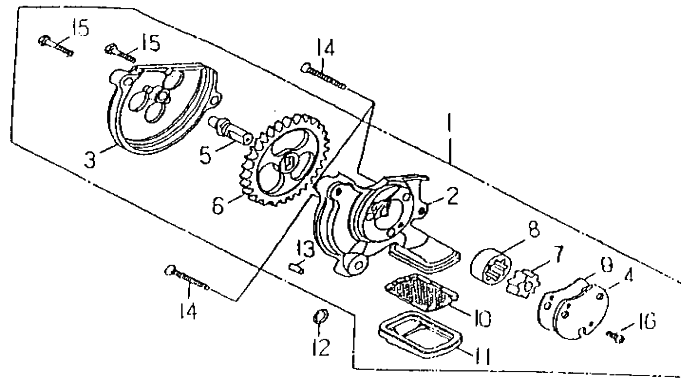

FIG.02 CRANKSHAFT.PISTON 曲轴.活塞

BMI  
MODEL:AAM-250E

NO	PARTS NO.	PARTS NAME	Q'TY
1	11400-CBT-00	CRANKSHAFT COMP	1
2	11631-CBT-00	PISTON	2
3	11636-CBT-00	RING SET, PISTON	2
4	13136-CBT-00	OIL PLATE, BREATHER	1
5	13178-CBT-00	OIL PUMP DRIVING WHEEL 20T	1
6	13321-CBT-00	THROUGH OIL	1
7	13324-CBT-00	SPRING, OIL THROUGH	1
8	25641-CBT-00	GEAR, PRIMARY DRIVE 19T	1
9	93110-35527	OIL SEAL TC 35*52*7	1
10	93210-30060	O-RING 3*6	1
11	93320-256217	BEARING, RADIAL BALL 6305	2
12	93510-101541	PIN, PISTON	2
13	94510-20014	PIN, DOWEL 2*13.8	1
14	94510-40004	PIN, DOWEL 4*3.7	1
15	94712-06016-B	SCREW, PAN HEAD 6*16	3
16	94717-06033-K	BOLT, ALIEN DIAMETER M7/M6*33	1
17	95201-162210-C	NUT, HEXAGON	1
18	95401-061006-C	NUT, FLANGE	1
19	96416-08032-K	BOLT, FLANGE 8*32	5
20	97050-10017	CIRCLIP, PISTON PIN	4
21	97310-162420-K	WASHER, CONICAL SPRING 16*23.9*2	1



**BMI**  
MODEL:AAM-250E

FIG.03 OIL PUMP 機油泵

NO	PARTS NO.	PARTS NAME	Q'TY
1	13100-CBT-00	PUMP ASS'Y, OIL	1
2	13111-CBT-00	BODY, OIL PUMP	1
3	13112-CBT-00	COVER, OIL PUMP GEAR	1
4	13116-CBT-00	PLATE, OIL PUMP	1
5	13121-CBT-00	SHAFT, OIL PUMP	1
6	13124-CBT-00	GEAR, OIL PUMP	1
7	13141-CBT-00	ROTOR, OIL PUMP INNER	1
8	13142-CBT-00	ROTOR, OIL PUMP OUTER	1
9	13151-CBT-00	GASKET, OIL PUMP	1
10	13310-CBT-00	ROTOR, OIL FILTER	1
11	13311-CBT-00	CAP, OIL FILTER ROTOR	1
12	93210-30060	O-RING 3*6	1
13	94510-40007	PIN, DOWEL 4*6.5	1
14	94712-06032-B	SCREW, FLAT HEAD 6*32	3
15	96210-05020-C	BOLT, HEXAGON 5*20	2
16	96318-05010-C	SCREW, PAN HEAD 5*10	1

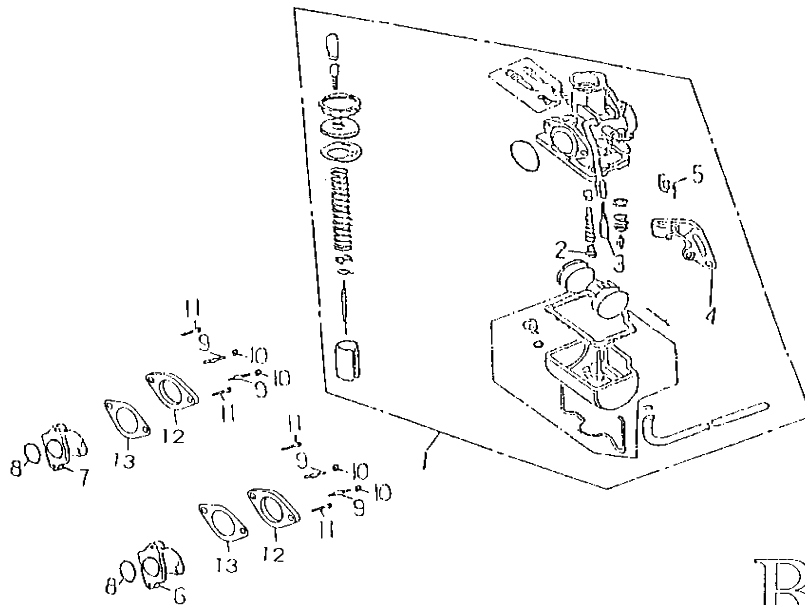

FIG.04 CARBURETOR 化油器

**BMI**  
MODEL:AAM-250E

NO	PARTS NO.	PARTS NAME	Q'TY
1	13201-RAM-01	CARBURETOR ASS'Y	2
2	13240-RAM-01	JET, MAIN #102	2
3	13242-RAM-00	JET, SLOW #35	2
4	13276-RAM-00	HOLDER, CHOKE CABLE	2
5	13278-RAM-00	SPRING, TORSION	2
6	13555-CBT-00	INSULATOR, CARB COMP L	1
7	13565-CBT-00	INSULATOR, CARB COMP R	1
8	93210-24262	O-RING 2.4*26.2	2
9	94717-06028-B	BOLT, STUD 6*28	4
10	95401-061006-B	NUT, FLANGE	4
11	96310-06020-B	SCREW, PAN HEAD 6*20	4
12	13620-CBT-00	INSULATOR CARBURETOR	2
13	13621-CBT-00	CARB, INSULATOR GASKET	2

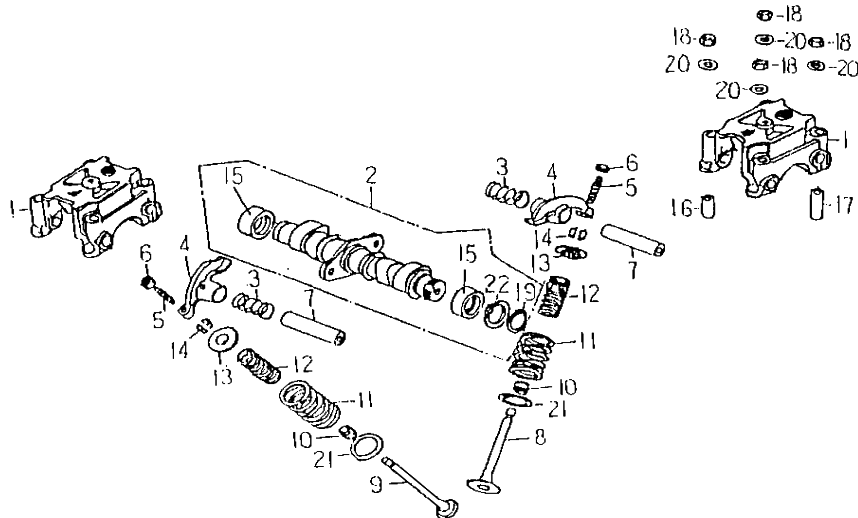

FIG.05 VALVE 閥門

BMII  
MODEL:AAM-250E

NO	PARTS NO.	PARTS NAME	Q'TY
1	11131-CBT-00	HOLDER, CAMSHAFT	2
2	14110-CBT-00	CAMSHAFT COMP	1
3	14150-CBT-00	SETTING SPRING, ROCKER ARM	2
4	14431-CBT-00	ARM, VALVE ROCKER	4
5	14436-CBT-00	SCREW, TAPPET ADJUSTING	4
6	14437-CBT-00	NUT, TAPPET ADJUSTING	4
7	14450-CBT-00	ROCKER ARM	2
8	14711-CBT-00	VALVE, IN	2
9	14721-CBT-00	VALVE, EX	2
10	14731-CBT-00	SEAL, VALVE STEM	4
11	14751-CBT-00	SEAL, VALVE OUTER	2
12	14761-CBT-00	SEAL, VALVE INNER	2
13	14771-CBT-00	RETAINER, VALVE SPRING	2
14	14781-CBT-00	COTTER, VALVE	4
15	93510-202813	SHEATH, CAMSHAFT	2
16	94410-10016	PIN, DOWEL 10*16	2
17	94410-10028	PIN, DOWEL 10*28	2
18	95201-081307-B	BOLT, HEXAGON	8
19	97010-20010-K	CIRCLIP 20 MM	1
20	97201-081822-B	WASHER, COPPER 8*5*18*2.2	8
21	97201-182610	SEAT, VALVE SPRING OUTER	4
22	97201-202719	WASHER, CAMSHAFT	1

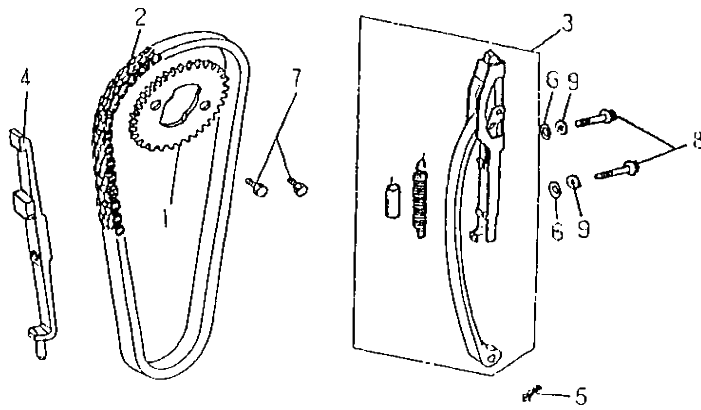

FIG.06 CAM CHAIN.TENSIONER 內鏈條.拉力桿

BMI  
MODEL:AAM-250E

NO	PARTS NO.	PARTS NAME	Q'TY
1	14111-CBT-00	SPROCKET, CAMSHAFT	1
2	14501-CBT-00	CHAIN, CAM	1
3	14510-CBT-00	TENSIONER, CAM CHAIN	1
4	14560-CBT-00	GUIDE COMP, CAM CHAIN	1
5	90230-12008	COTTER PIN	1
6	93210-19058	O-RING 1.9*5.8	2
7	94706-07014-K	BOLT, HEXAGON 7*14	2
8	96414-06025-B	BOLT, FLANGE 6*25	2
9	97230-061312	WASHER, COPPER 6.2*13*1.2	2

BMI  
MODEL : AAM-250E

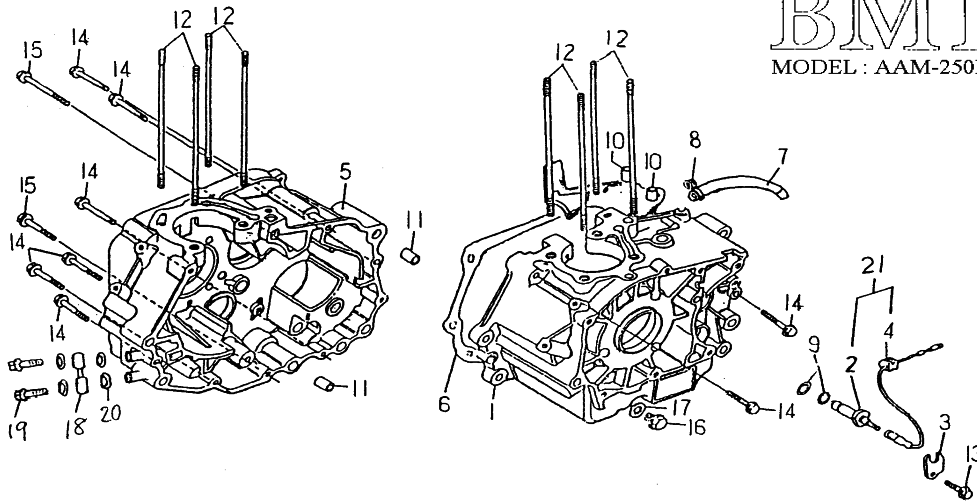
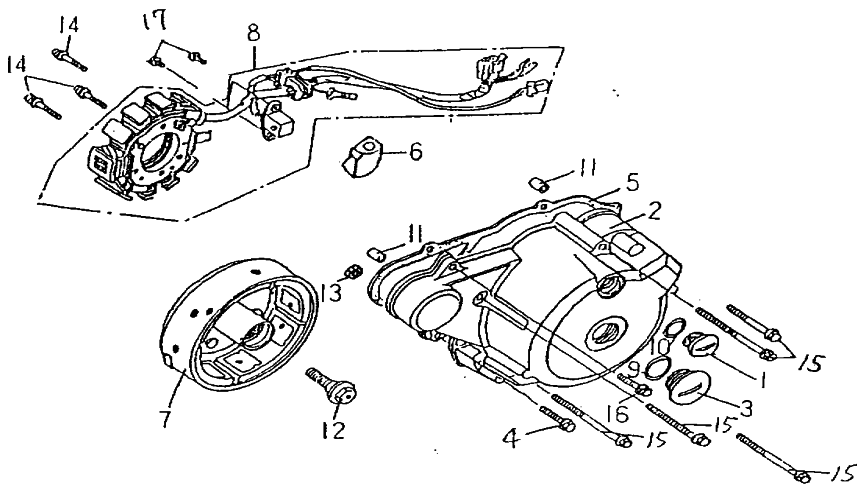

FIG.07 CRANKCASE 曲軸箱

NO	PARTS NO.	PARTS NAME	Q'TY
1	15111-CBT-00	CRANKCASE, LEFT	1
2	15127-CBT-00	CONTACT, NEUTRAL SWITCH	1
3	15128-CBT-00	CLAMPER, WIRE HARNESS	1
4	15129-CBT-00	CONTACT ASS'Y, NEUTRAL SWITCH	1
5	15211-CBT-00	CRANKCASE, RIGHT	1
6	15251-CBT-00	GASKET, CRANKCASE	1
7	15276-CBT-00	HOSE	1
8	90210-15016-B	CLIP	1
9	93210-16070	O-RING 1.6*7	2
10	94410-08014	PIN, DOWEL 8*14	2
11	94410-12020	PIN, DOWEL 12*20	2
12	94717-08215-B	BOLT, STUD 8*215	8
13	96411-06012-C	BOLT, FLANGE 6*12	1
14	96411-06040-R	BOLT, FLANGE 6*40	8
15	96414-06065-B	BOLT, FLANGE 6*65	2
16	96414-12015-B	BOLT, FLANGE 12*15	1
17	97231-122118	WASHER, ALUMINUM 12.5*20.6*1.8	1
18	61920-CBT-00	CONNECTOR,OIL COOLING HOLE	1
19	94716-12032-G	BOLT,UNION M12*32L	2
20	97231-122020	WASHER,ALUMINUM 12.3*20*2.0	4
21	15126-CBT-00	ASS'Y CONTACT, NEUTRAL SWITCH	1



**BMI**  
MODEL : AAM-250E

FIG.08 LEFT CRANKCASE COVER 左曲軸箱蓋

NO	PARTS NO.	PARTS NAME	Q'TY
1	12655-CBT-00	CAP, A.C.G	1
2	15411-CBT-00	COVER, L CRANKCASE	1
3	15417-CBT-00	CAP, L CRANKCASE COVER	1
4	96414-06050-R	BOLT,FLANGE 6*50	1
5	15481-CBT-00	GASKET, L CRANKCASE COVER	1
6	15541-CBT-00	ENGINE OUTPUT WIRE JACKET	1
7	35550-CBT-00	FLYWHEEL COMP	1
8	35560-CBT-00	STATOR COMP	1
9	93210-24274	O-RING 2.4*27.4	1
10	93210-25138	O-RING 2.5*13.8	1
11	94410-08016	PIN, DOWEL 8*16	2
12	94716-10033-B	BOLT, CRANKSHAFT	1
13	95401-061006-B	NUT, FLANGE	1
14	96312-05028-B	SCREW, PAN HEAD WITH WASHER	3
15	96411-06065-R	BOLT, FLANGE 6*65	1
16	96411-06020-R	BOLT, FLANGE 6*20	1
17	96510-06020-B	BOLT, FLANGE 6*20	1



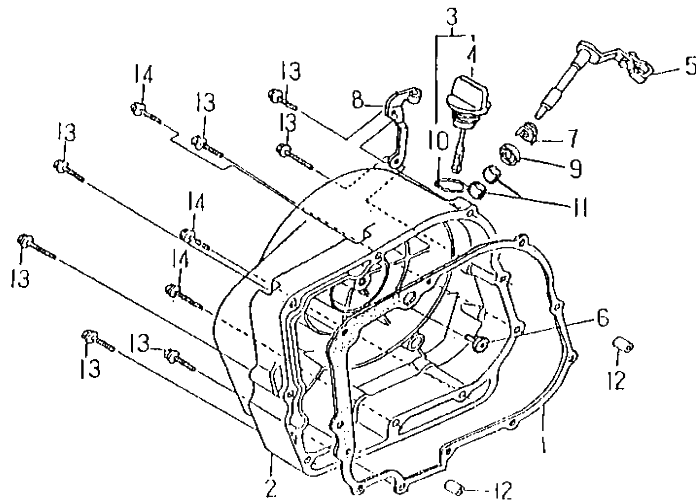

**BMII**  
MODEL:AAM-250E

FIG.09 RIGHT CRANKCASE COVER 右曲軸箱蓋

NO	PARTS NO.	PARTS NAME	Q'TY
1	15221-CBT-00	GASKET, R CRANKCASE COVER	1
2	15511-CBT-00	COVER, R CRANKCASE COMP	1
3	15561-CBT-00	GAUGE ASS'Y, OIL LEVEL	1
4	15563-CBT-00	GAUGE, OIL LEVEL	1
5	25723-CBT-00	LEVER, CLUTCH	1
6	25732-CBT-00	PUSHING PLATE	1
7	25753-CBT-00	SPRING CLUTCH LEVER	1
8	25793-CBT-00	HOLDER, CLUTCH WIRE	1
9	93110-12185	OIL SEAL KC 12*18*5	1
10	93210-35178	O-RING 3.5*17.8	1
11	93310-1216100	BEARING, NEEDLE (HK-121610)	2
12	94410-08014	PIN, DOWEL 8*14	2
13	96411-06040-B	BOLT, FLANGE 6*40	7
14	96411-06050-B	BOLT, FLANGE 6*50	3

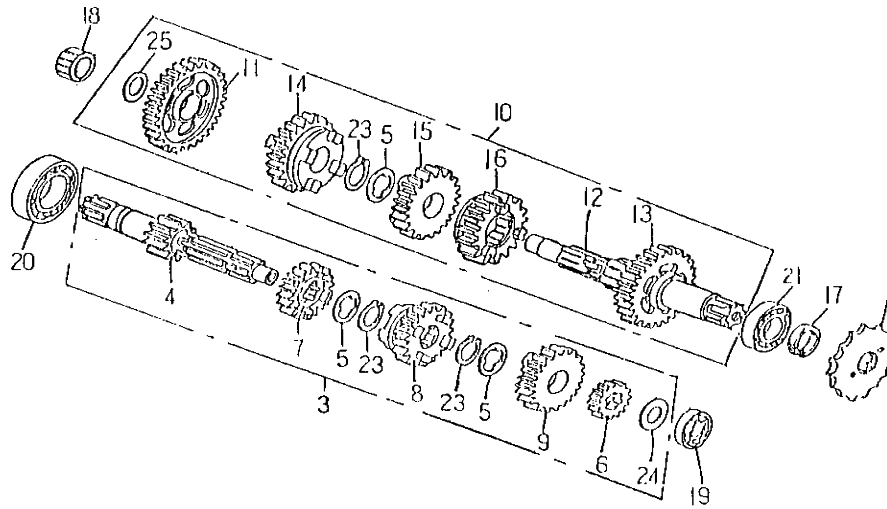

**BMI**  
MODEL : AAM-250E

FIG.10 TRANSMISSION.STARTER 傳動系統

NO	PARTS NO.	PARTS NAME	Q'TY
1	25711-CBT-00	SPROCKET DRIVE 14T	1
3	26100-CBT-00	MAIN SHAFT ASS'Y	1
4	26111-CBT-00	MAIN SHAFT, TRANSMISSION 13T	1
5	26118-CBT-00	WASHER, SPLINE	3
6	26120-CBT-00	GEAR, MAIN SHAFT SECOND 18T	1
7	26130-CBT-00	GEAR, MAIN SHAFT THIRD 21T	1
8	26140-CBT-00	GEAR, MAIN SHAFT FOURTH 24T	1
9	26150-CBT-00	GEAR, MAIN SHAFT FIFTH 23T	1
10	26400-CBT-00	COUNTER SHAFT ASS'Y	1
11	26410-CBT-00	GEAR, COUNTER SHAFT LOW 37T	1
12	26411-CBT-00	COUNTER SHAFT, TRANSMISSION	1
13	26420-CBT-00	GEAR, COUNTER SHAFT SECOND 32T	1
14	26430-CBT-00	GEAR, COUNTER SHAFT THIRD 28T	1
15	26440-CBT-00	GEAR, COUNTER SHAFT FOURTH 26T	1
16	26450-CBT-00	GEAR, COUNTER SHAFT FIFTH 21T	1
17	93110-22347	OIL SEAL TC 22*34*7	1
18	93310-1521120	BEARING, NEEDLE(NK-15/12)	1
19	93310-205215	BEARING, NEEDLE 6304	1
20	93320-153511Z	BEARING, RADIAL BALL 6202Z	1
21	93320-224714B	BEARING, RADIAL 22*47*14-RS	1
23	97014-20012-K	CIRCLIP 20MM	3
24	97201-152510-K	WASHER, THRUST 15.4*24.8*1	1
25	97201-153317	WASHER, THRUST 15.2*32.8*1.7	1

# BMI

MODEL : AAM-250E

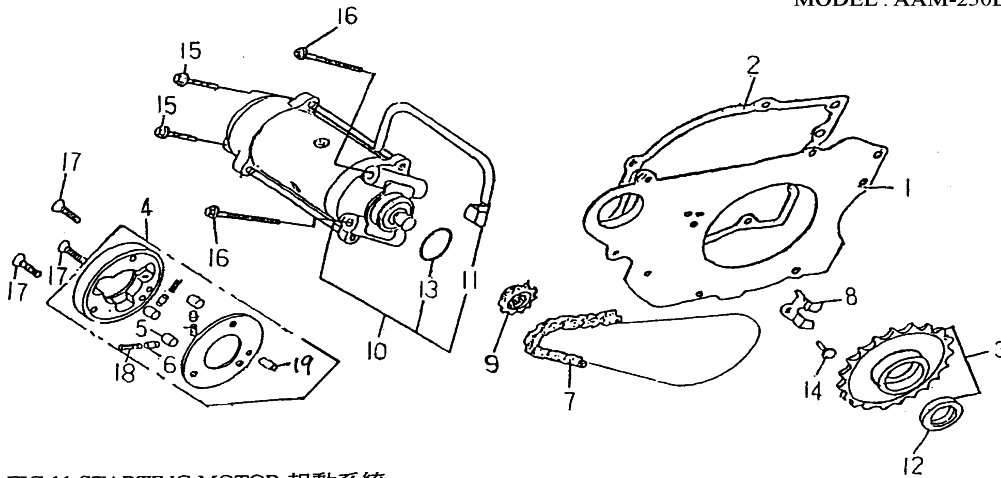

FIG.11 STARTING MOTOR 起動系統

NO	PARTS NO.	PARTS NAME	Q'TY
1	15431-CBT-00	CLAPBOARD	1
2	15483-CBT-00	CLAPBOARD GASKET	1
3	23524-CBT-00	GEAR COMP, STARTING CLUTCH 38T	1
4	23570-CBT-00	STARTING CLUTCH ASS'Y	1
5	23576-CBT-00	ROLLER 10*9.5	3
6	23578-CBT-00	CAP, STARTING CLUTCH ROLER SPRING	3
7	23612-CBT-00	MOTOR DRIVE CHAIN	1
8	23632-CBT-00	PALTE, SET GEAR	1
9	23660-CBT-00	MOTOR SPROCKET WHEEL 13T	1
10	35800-CBT-00	MOTOR ASS'Y, STARTER	1
11	35831-CBT-00	CABLE, STARTER MOTOR	1
12	93110-22315	OIL SEAL SC 22*31*5	1
13	93210-18335	O-RING 1.8*33.5	1
14	96411-06012-C	BOLT, FLANGE 6*12	1
15	96411-06025-R	BOLT, FLANGE 6*25	2
16	96411-06065-R	BOLT, FLANGE 6*65	2
17	96510-06016-C	BOLT, FLANGE 6*16	3
18	97501-03029	SPRING, STARTING CLUTCH ROLLER	3
19	94510-60014	PIN,DOWEL 6*14	1

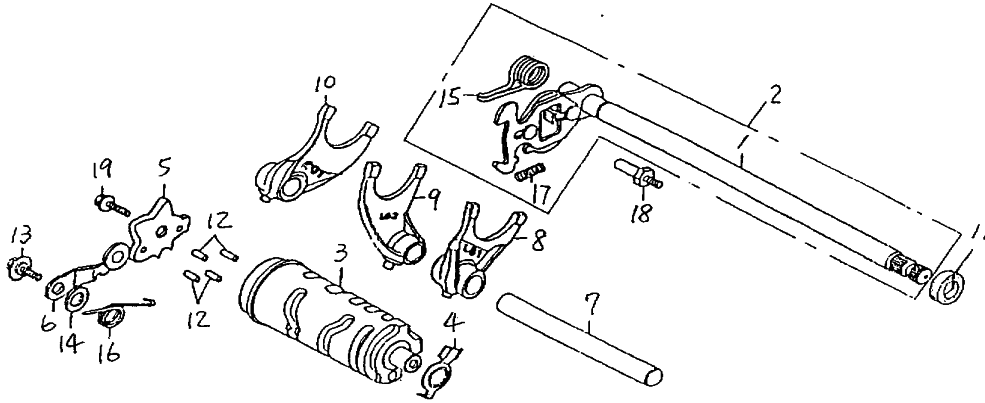
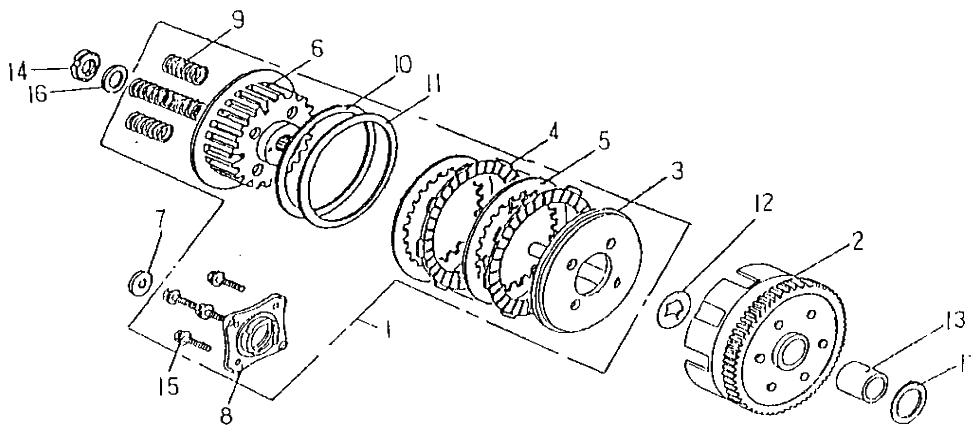

FIG.12 GEAR SHIFT 變速機構

BMI  
MODEL : AAM-250E

NO	PARTS NO.	PARTS NAME	Q'TY
1	24201-CBT-00	SPINDLE, GEAR SHIFT	1
2	24210-CBT-00	SPINDLE COMP, GEAR SHIFT	1
3	24220-CBT-00	DRUM, GEAR SHIFT	1
4	24223-CBT-00	POTOR, NEUTRAL SWITCH	1
5	24226-CBT-00	CAM, GEAR SHIFT	1
6	24228-CBT-00	STOPPER COMP, GEAR SHIFT	1
7	24236-CBT-00	SHAFT, GEAR SHIFT FORK	1
8	24237-CBT-00	FORK, L GEAR SHIFT	1
9	24238-CBT-00	FORK, CENTER GEAR SHIFT	1
10	24239-CBT-00	FORK, R GEAR SHIFT	1
11	93110-112410	OIL SEAL TC 11.6*24*10	1
12	94510-40013	PIN, DOWEL 4*13	4
13	96411-06020-C	BOLT, FLANGE 6*20	1
14	97201-061612-K	WASHER, THRUST 6.4*15.8*1.2	2
15	97501-05020	SPRING, GEAR SHIFT PLATE	1
16	97508-23153	SPRING, SHAFT DRUM STOPP	1
17	97510-32179	SPRING, GEAR SHIFT RETURN	1
18	24216-CBT-00	TIP POLE	1
19	94710-06014-K	SCREW	1



**BMI**  
MODEL:AAM-250E

FIG.13 CLUTCH 離合器

NO	PARTS NO.	PARTS NAME	Q'TY
1	25602-CBT-00	CLUTCH COMP	1
2	25611-CBT-00	OUTER COMP, CLUTCH	1
3	25621-CBT-00	PLATE, CLUTCH PRESSURE	1
4	25622-CHP-00	DISK, CLUTCH FRICITION	6
5	25623-CBT-00	PLATE, CLUTCH PRESSURE	6
6	25661-CBT-00	CENTER, CLUTCH	1
7	25666-CBT-00	BEARING, NEEDLE	1
8	25670-CBT-00	PLATE, CLUTCH LIFTER	1
9	25680-CBT-00	SPRING, CLUTCH	4
10	25684-CBT-00	GASKET	1
11	25686-CBT-00	WASHER	1
12	25688-CHP-00	WASHER, SPLINE	1
13	93510-202618	BEARING, SHEATH	1
14	95601-162808-K	NUT, RING	1
15	96414-06022-B	BOLT, FLANGE 6*22	4
16	97310-162720	WASHER, THRUST 16.5*26.4*2	1
17	97201-203520	WASHER, THRUST 20.2*35*2	1

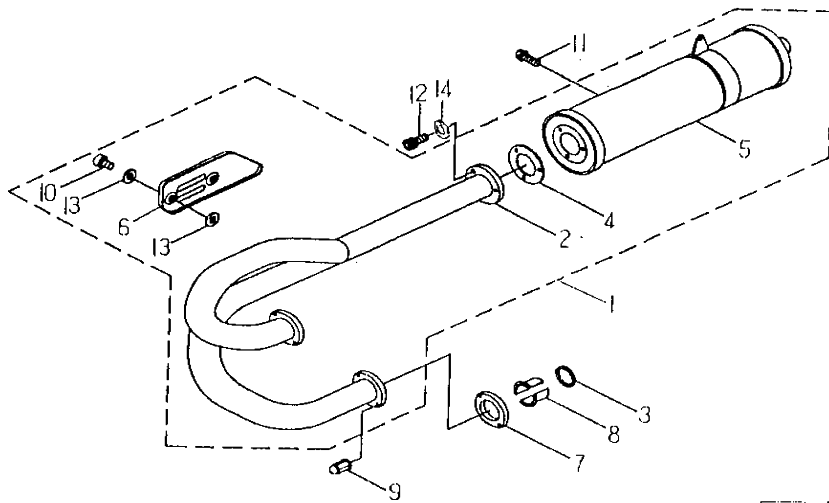

**BMI**  
MODEL: AAM-250E

FIG.14 EXHAUST MUFFLER 排氣管

NO	PARTS NO.	PARTS NAME	Q'TY
1	31610-CBT-01	EXHAUST MUFFLER ASS'Y	1
2	31611-CBT-00	PIPE,EXHAUST	1
3	31613-CHP-00	GASKET,EXHAUST PIPE 31.5*39.5*3.5	2
4	31614-RAM-00	GASKET,MUFFLER	1
5	31617-CBT-01	MUFFLER COMP	1
6	31618-CBT-00	PROTECTOR,EXHAUST	1
7	31621-CBT-00	JOINT,EXHAUST PIPE	2
8	31623-CBT-00	COLLAR,EXHAUST PIPE JOINT	4
9	95401-081208-B	NUT,FLANGE	4
10	96316-06010-K	.SCREW,PAN HEAD	2
11	96414-08016-B	BOLT,FLANGE	1
12	96510-06020-K	BOLT,SOCKET	3
13	97210-061215	WASHER,PLATE	4
14	97301-061115-K	WASHER,SPRING 6.5*11*1.5	3

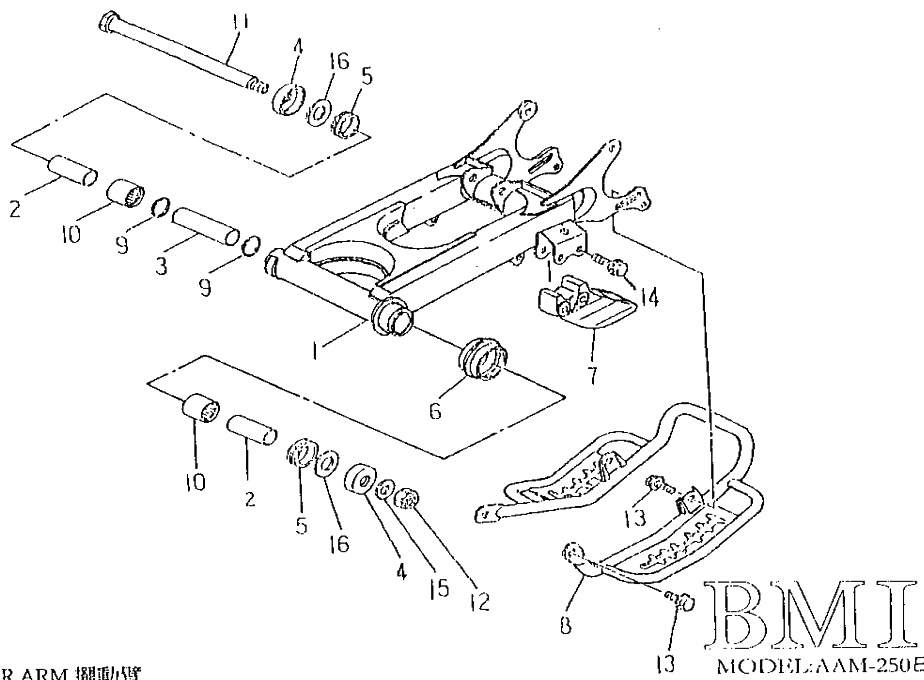
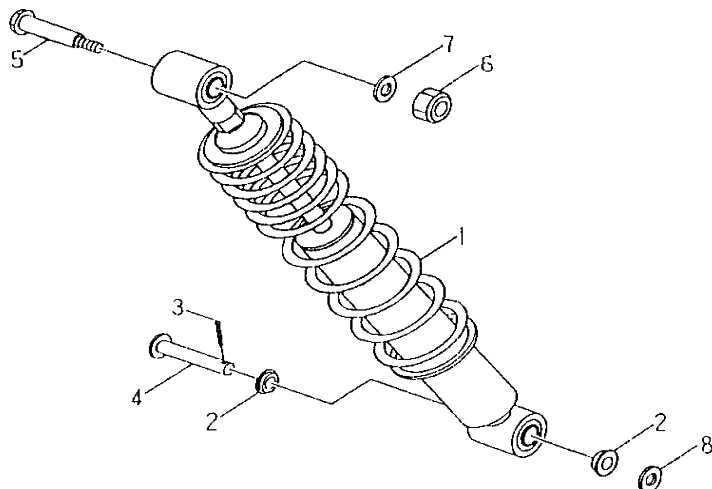

FIG.15 REAR ARM 擺動臂

BMII  
MODEL AAM-250E

NO	PARTS NO.	PARTS NAME	Q'TY
1	32100-RAM-00	REAR ARM	1
2	32115-RAM-00	BUSH	2
3	32116-RAM-00	SPACER	1
4	32118-RAM-00	COVER,THRUST	2
5	32119-RAM-00	OIL SEAL	2
6	32160-RAM-00	SEAL, GUARD	1
7	32165-RAM-00	SUPPORT, CHAIN	1
8	32190-RAM-00	COVER	1
9	93210-25200	O-RING 2.5*20	2
10	93310-222820	BEARING, NEEDLE ROLLER HK-2220	2
11	94610-15258-B	SHAFT, PIVOT	1
12	95301-142212-B	NUT, LOCK 14MM	1
13	96414-08012-B	BOLT, FLANGE	4
14	96414-08040-B	BOLT, FLANGE	2
15	97201-142820-B	WASHER, PLATE 14.2*28.4*2.0	1
16	97201-243820	WASHER, PLATE	2



**BMI**  
MODEL:AAM-250E

FIG.16 REAR SUSPENSION 後懸吊系統

NO	PARTS NO.	PARTS NAME	Q'TY
1	32210-CBT-02	SHOCK ABSORBER ASS'Y,REAR	1
2	32231-RAM-00	COVER,THRUST	2
3	90240-29025-B	PIN.COTTER 2.9*25	1
4	94610-12070-B	PIN,CLEVIS	1
5	94710-10066-B	BOLT	1
6	95311-101710-B	NUT,NYLON	1
7	97201-102220-B	WASHER.PLATE 10.5*22*2	1
8	97201-122223-B	WASHER,PLATE 12.5*22*2.3	1



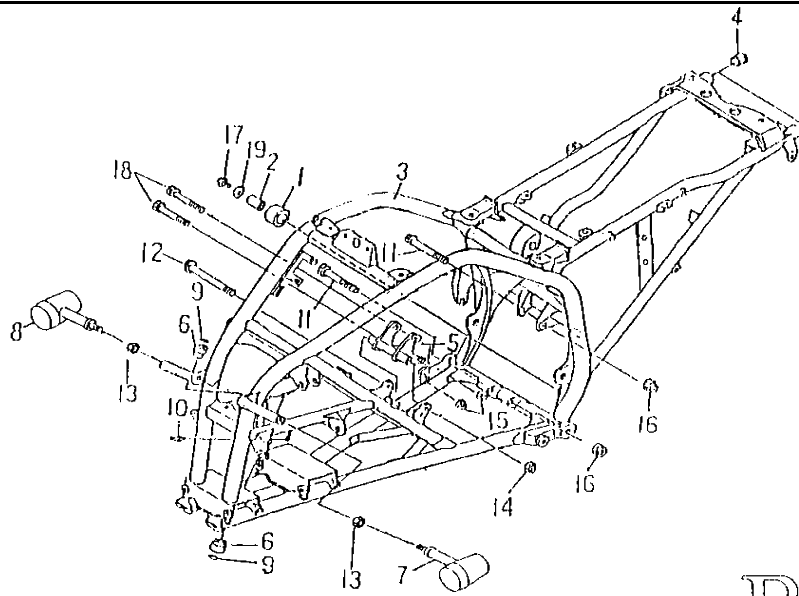

**BMU**  
MODEL:AAM-250E

FIG.17 FRAME 車架

NO	PARTS NO.	PARTS NAME	Q'TY
1	32167-RAM-00	TENSIONER	2
2	32168-RAM-00	BUSH	2
3	41110-CBT-03	FRAME COMP	1
4	41154-RAM-00	PLUG,SPECIAL SHAPE	2
5	41181-CBT-00	ENGINE HANGER F	1
6	46412-RAM-00	BUSH,SOLID	2
7	55350-RAM-00	WINKER ASS'Y,L/H FRONT	1
8	55360-RAM-00	WINKER ASS'Y,R/H FRONT	1
9	93210-24148	O-RING 2.4*14.8	2
10	94340-06010-B	NIPPLE,GREASE M6*P1.0	1
11	94610-10113-B	BOLT,FLANGE	2
12	94610-12125-B	BOLT,FLANGE	1
13	95201-101408-B	NUT,HEXAGON	2
14	95311-121912-B	NUT,NYLON	1
15	95401-081208-B	NUT,FLANGE	2
16	95401-101409-B	NUT,FLANGE	2
17	96414-08012-B	BOLT,FLANGE	2
18	96414-10070-B	BOLT,FLANGE	2
19	97201-082420-B	WASHER,PLATE 8.7*24*2.0	2

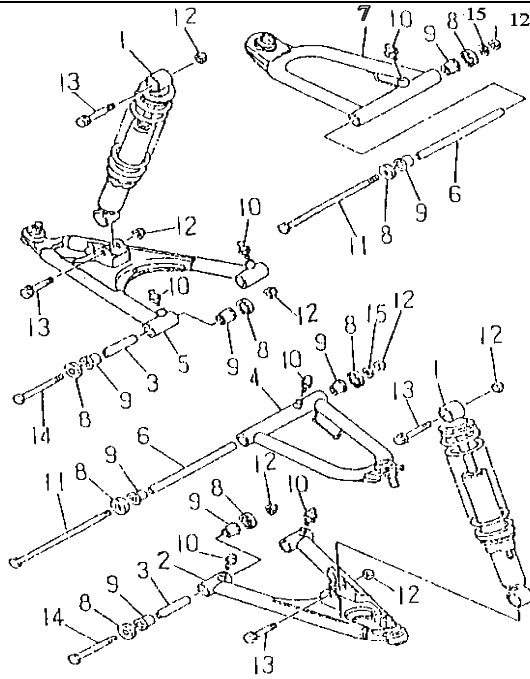

BMI  
MODEL:AAM-250E

FIG.18 FRONT SUSPENSION 前懸吊系統

NO	PARTS NO.	PARTS NAME	Q'TY
1	42126-RAM-00	SHOCK ABSORBER ASS'Y	2
2	42161-RAM-00	FRT.LWR,ARM LEFT	1
3	42163-RAM-00	COLLAR	4
4	42166-RAM-00	FRT.UPPER,ARM LEFT	1
5	42171-RAM-00	FRT.LWR,ARM RIGHT	1
6	42173-RAM-00	COLLAR	2
7	42176-RAM-00	FRT.UPPER,ARM RIGHT	1
8	42183-RAM-00	COVER,THRUST	12
9	93330-152118	BUSH,SOLID	12
10	94340-06010-B	NIPPLE,GREASE M6*P1.0	6
11	94610-10208-B	SHAFT,PIVOT	2
12	95311-101710-B	NUT,NYLON	10
13	96414-10055-B	BOLT,FLANGE	4
14	96414-10080-B	BOLT,FLANGE	4
15	97201-102020-B	WASHER,PLATE 10.5*20*2	6

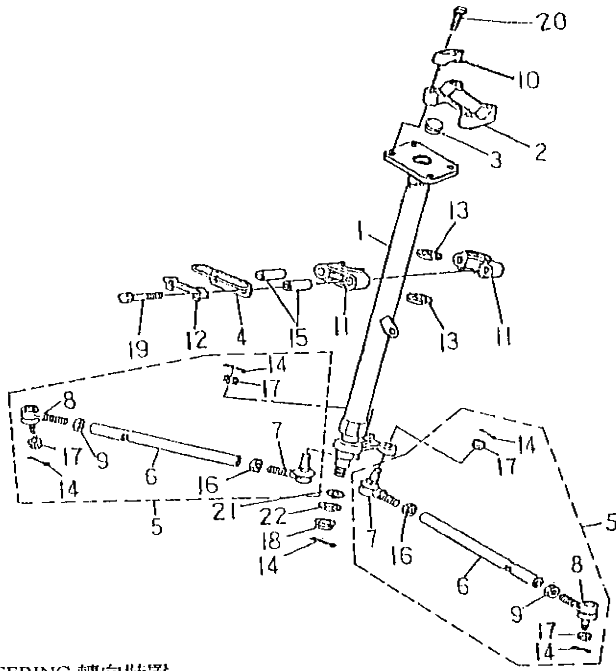

FIG.19 STEERING 轉向裝置

**BMI**  
MODEL:AAM-250E

NO	PARTS NO.	PARTS NAME	Q'TY
1	42101-RAM-02	COLUMN,STEERING	1
2	42106-SK9-00	BRIDGE, TOP	1
3	42111-RAM-00	PLUG,TAPER	1
4	42118-RAM-00	BRACKER,STRG LOWER	1
5	42140-RAM-00	ROD,TIE ASS'Y	2
6	42141-RAM-00	ROD,TIE	2
7	42142-RAM-00	JOINT,UNIVERSAL 1	2
8	42143-RAM-00	JOINT,UNIVERSAL 2	2
9	42146-RAM-00	NUT	2
10	46125-RAM-00	HOLDER,HANDLE UPR	2
11	46411-RAM-00	BEARING,STEERING	2
12	46416-RAM-00	WASHER,LOCK	1
13	46417-RAM-00	OIL SEAL	2
14	90240-23020-B	PIN,COTTER 2.3*20	5
15	93510-081442-C	COLLAR	2
16	95201-101408-C	NUT,HEXAGON	2
17	95321-101710-C	NUT,CASTLE	4
18	95401-101409-B	NUT,NYLON	1
19	96210-08060-B	BOLT,HEXAGON	2
20	96414-08050-B	BOLT,FLANGE	4
21	97201-102620-B	WASHER,PLATE	1
22	97301-101720-B	WASHER,SPRING	1

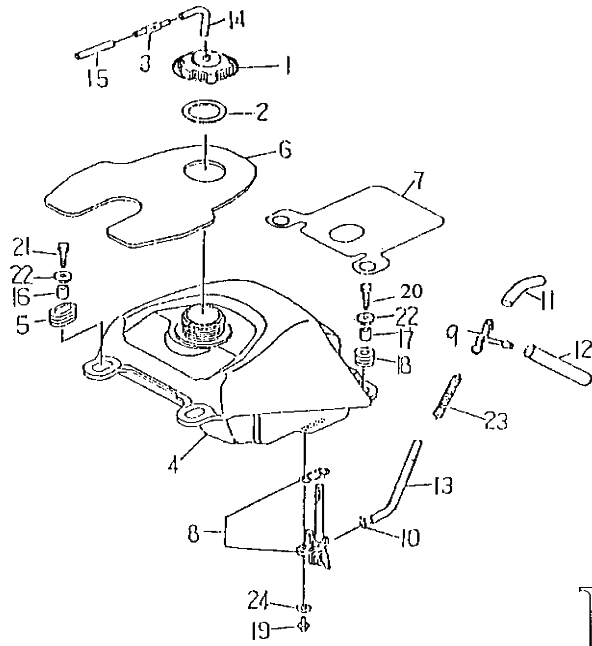
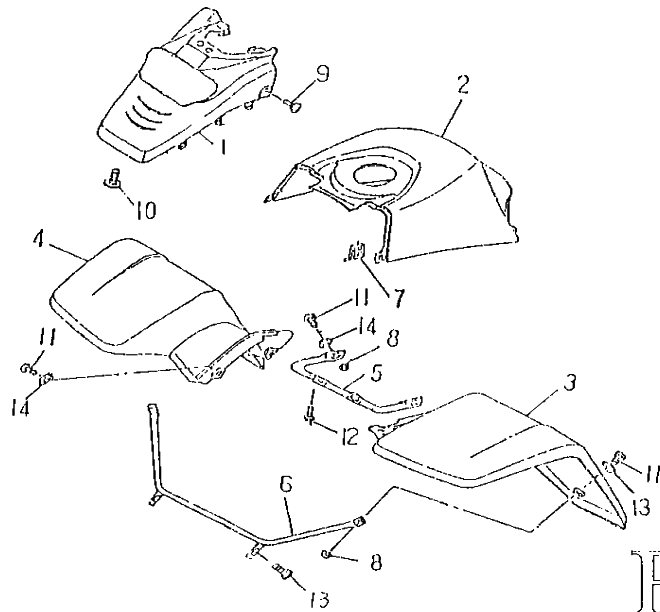

FIG.20 FUEL TANK 油箱

BMI  
MODEL:AAM-250E

NO	PARTS NO.	PARTS NAME	Q'TY
1	43102-RAM-00	CAP ASS'Y	1
2	43103-RAM-00	CAP WASHER	1
3	43108-SK5-00	CHECK, VALVE	1
4	43110-CBT-01	FUEL TANK	1
5	43151-RAM-00	GROMMET F	2
6	43153-RAM-00	TRIM, COVER PANEL	1
7	43154-RAM-00	GUARD	1
8	43500-CBT-00	FUEL COCK ASS'Y	1
9	43535-CBT-00	JOINT THREE WAY	1
10	90210-12010	CLIP	3
11	90310-50060	HOSE, FUEL	1
12	90310-50135	HOSE, FUEL	1
13	90310-50140	HOSE, FUEL	1
14	90310-50050	HOSE 5*8*50	1
15	90310-50390	HOSE 5*8*390	2
16	93510-061015-B	COLLAR F	2
17	93510-061021-B	COLLAR R	2
18	93580-102416	GROMMET R	2
19	96318-06012-B	SCREW, PAN HEAD	2
20	96414-06025-B	BOLT, FLANGE	2
21	96414-06032-B	BOLT, FLANGE	2
22	97201-062220-B	WASHER, PLATE	4
23	97501-08140-B	SPRING, COMPRESSION	1
24	97210-061315	WASHER, PLATE	2



FOR AAM

FIG.21 FRONT FENDER 前土除

**BMII**  
MODEL AAM-250 E

NO	PARTS NO.	PARTS NAME	Q'TY
1	51151-AAM-00	PANEL,FRONT	1
2	51532-RAM-00	COVER, TOP	1
3	51552-RAM-00	FENDER,FRONT L	1
4	51553-RAM-00	FENDER,FRONT R	1
5	51554-RAM-00	STAY,FENDER UPPER	1
6	51556-CBT-00	SYAT,FENDER LOWER	1
7	95101-05012	NUT,SPRING	2
8	95401-061006-B	NUT,FLANGE	4
9	96112-51216-K	SCREW,TAPPING	2
10	96318-06012-B	SCREW,PAN HEAD	1
11	96318-06015-B	SCREW,PAN HEAD	6
12	96414-06012-B	BOLT,FLANGE	2
13	96414-06016-B	BOLT,FLANGE	2
14	97321-061825-B	WASHER,FLANGE	6

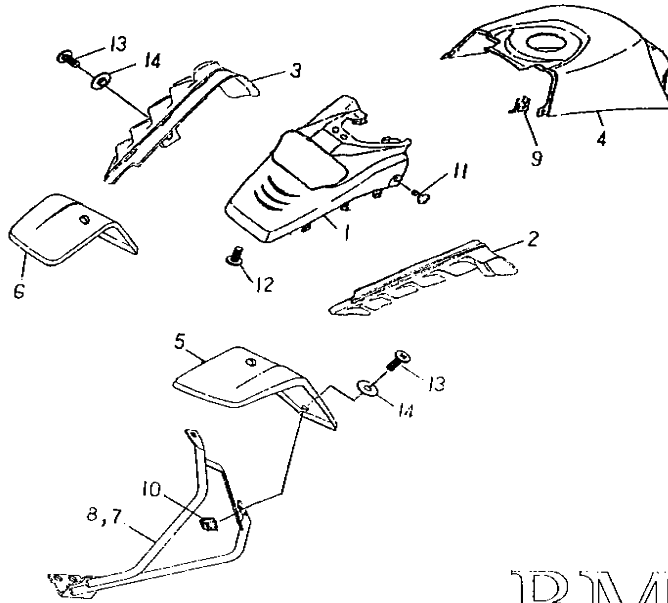

FOR ATG

FIG.21 FRONT FENDER 前土除

**BMII**  
MODEL:AAM-250E

NO	PARTS NO.	PARTS NAME	Q'TY
1	51151-AAM-0007	PANEL,FRONT	1
2	51162-STG-0007	COVER,LEFT TOOL	1
3	51163-STG-0007	COVER,RIGHT TOOL	1
4	51532-RAM-0007	COVER,TOP	1
5	51552-STG-0007	FENDER,FRONT L	1
6	51553-STG-0007	FENDER,FRONT R	1
7	51554-STG-00	STAY,FENDER L	1
8	51556-STG-00	STAY,FENDER R	1
9	95101-05012	NUT,SPRING	2
10	95401-061006-B	NUT,FLANGE	4
11	96112-51216-K	SCREW,TAPPING	2
12	96318-06012-B	SCREW,PAN HEAD	1
13	96318-06015-B	SCREW,PAN HEAD	6
14	97321-061825-B	WASHER,FLANGE	6

**BMI**  
MODEL : AAM-250E

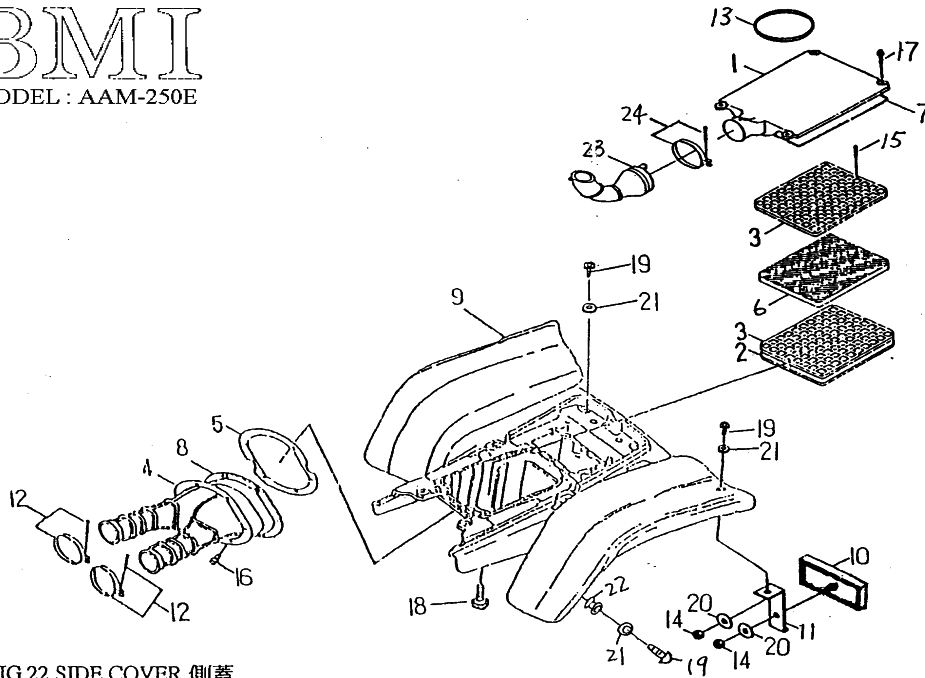
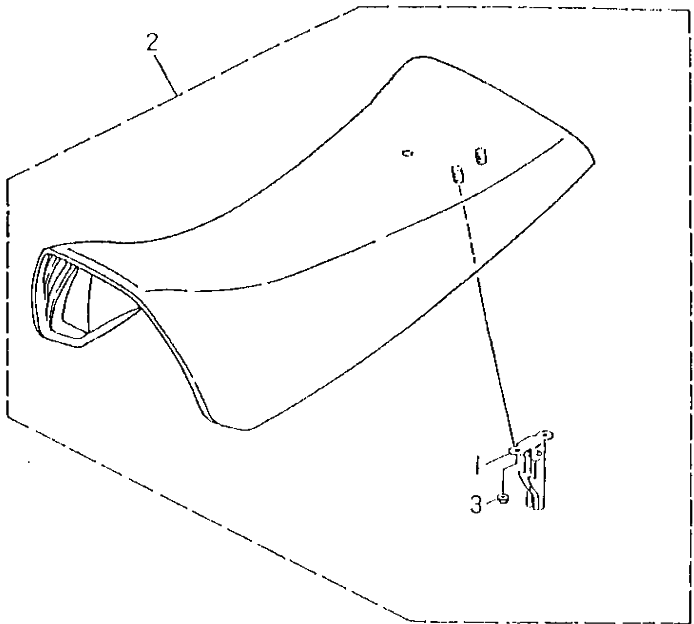

FIG.22 SIDE COVER 側蓋

NO	PARTS NO.	PARTS NAME	Q'TY
1	13412-CBT-00	CAP,CLEANER CASE	1
2	13432-RAM-00	SEAL,ELEMENT	1
3	13433-CBT-00	PLATE,ELEMENT SET	2
4	13434-RAM-00	PLATE,JOINT	1
5	13435-RAM-00	STAY,JOINT	1
6	13451-RAM-00	ELEMENT,AIR CLEANER	1
7	13452-RAM-00	SEAL,AIR CLEANER COVER	1
8	13453-CBT-00	TUBE,AIR CLEANER JOINT	1
9	51171-RAM-00	COVER,SIDE	1
10	55722-SAF-00	REFLECTOR	2
11	55724-RAM-00	STAY,REFLECTOR	2
12	90260-80047	CLAMP,HOSE	2
13	93210-35900	O-RING	1
14	95401-061006-B	NUT,FLANGE	4
15	96110-43018-K	SCREW,TAPPING	8
16	96310-05014-B	SCREW,PAN HEAD	6
17	96313-06020-K	SCREW,PAN HEAD WITH WASHER	4
18	96318-06012-B	SCREW,PAN HEAD	1
19	96318-06015-B	SCREW,PAN HEAD	6
20	97301-061215-B	WASHER,SPRING 6*11.5*1.5	4
21	97321-061825-B	WASHER,FLANGE	8
22	93580-81610	GROMMET	2
23	13437-CBT-00	GROMMET	1
24	90260-80057	CLAMP,HOSE	1



BMI  
MODEL:AAM-250E

FIG.23 SEAT 座墊

NO	PARTS NO.	PARTS NAME	Q'TY
1	52710-RAM-00	CATCH COMP,SEAT	1
2	52730-CBT-02	SINGLE SEAT ASS'Y-BAROSSA	1
3	95401-061006-C	NUT,FLANGE	2



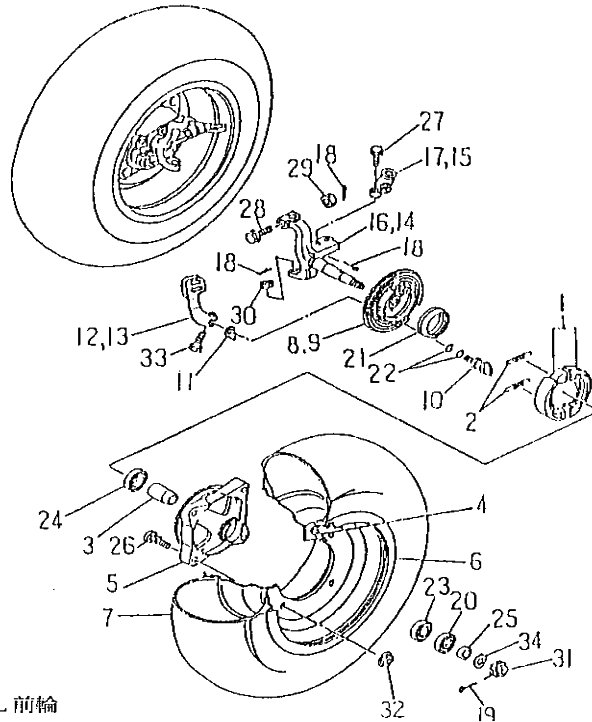
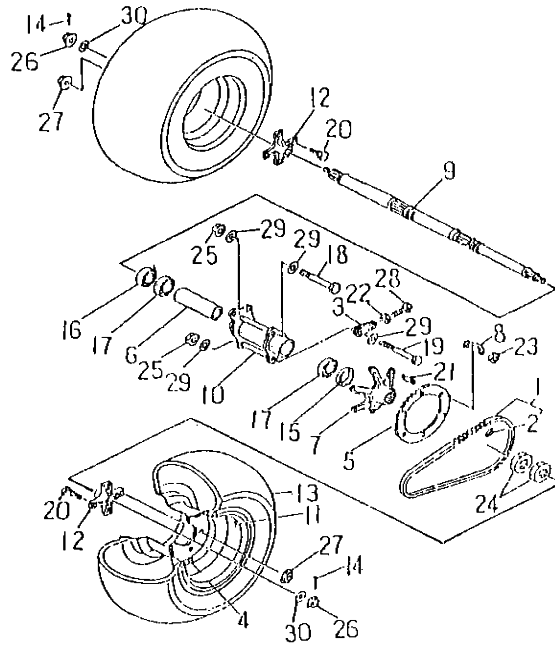

FIG.24 FRONT WHEEL 前輪

BMII  
MODEL:AAM-250E

NO	PARTS NO.	PARTS NAME	Q'TY
1	32345-NAF-00	BRAKE SHOE SET	2
2	32346-NAF-00	SPRING,TENSION	4
3	42515-RAM-00	SPACER,BEARING	2
4	42570-RAM-00	VALVE,RIM	2
5	42581-RAM-00	HUB,FRONT	2
6	42582-RAM-00	WHEEL,FRONT 10*5.5AT	2
7	42590-RAM-03	TIRE,FRONT AT21*7-10 K546F	2
8	45811-RAM-01	PLATE,BRAKE SHOE L	1
9	45821-RAM-01	PLATE,BRAKE SHOE R	1
10	45851-RAM-00	CAMSHAFT	2
11	45853-RAM-00	PLATE,INDICATOR	2
12	45855-RAM-01	LEVER,CAMSHAFT L	1
13	45856-RAM-01	LEVER,CAMSHAFT R	1
14	45861-RAM-00	KNUCKLE,STEERING L	1
15	45862-RAM-00	JOINT,ROD L	1
16	45866-RAM-00	KNUCKLE,STEERING R	1
17	45867-RAM-00	JOINT,ROD R	1
18	90240-23020-B	PIN,COTTER 2.3*20	8
19	90240-29025-B	PIN,COTTER 2.9*25	2
20	93110-22357	OIL SEAL SD22*35*7	2
21	93110-50627	OIL SEAL SDD 50*62*7	2
22	93210-24118	O-RING 2.4*11.8	4
23	93320-153511S	BEARING,RADIAL BALL 6202 CS05/2A	2
24	93320-203709S	BEARING,RADIAL BALL 6904 CM/2A	2
25	93510-152209-C	COLLAR	2
26	94710-10032-C	BOLT,STUD	8
27	94716-10030-C	BOLT,KEYHOLE	4
28	94716-10040-C	BOLT,KEYHOLE	2
29	95311-101710-C	NUT,NYLON	2
30	95321-101710-C	NUT,CASTLE	2
31	95321-142215-C	NUT,CASTLE	2
32	95401-101409-C	NUT,FLANGE	8

33	96210-06030-B	BOLT,HEXAGON	2
34	97201-142820-C	WASHER,PLATE 14.2*28.4*2	2



**BMI**  
MODEL:AAM-250E

FIG.25 REAR WHEEL 後輪

NO	PARTS NO.	PARTS NAME	Q'TY
1	25741-CBT-00	CHAIN 520H*94L	1
2	25742-RAM-00	JOINT,CHAIN	1
3	32120-RAM-00	ADJUSTER,CHAIN	2
4	42570-RAM-00	VALVE,RIM	2
5	42812-RAM-00	SPROCKET,DRIVEN 40T	1
6	42815-RAM-00	SPACKER,BEARING	1
7	42821-RAM-00	COLLAR,SPROCKET AXLE	1
8	42823-RAM-00	WASHER,LOCK	3
9	42835-RAM-00	AXLE,WHEEL	1
10	42881-RAM-00	HUB,REAR	1
11	42882-RAM-00	WHEEL,REAR 8*8.0AT	2
12	42885-RAM-00	COLLAR,WHEEL	2
13	42890-RAM-04	TIRE,REAR AT21*10-8 (K547)	2
14	90240-29025-B	PIN,COTTER 2.9*25	2
15	93110-42628	OIL SEAL 42*62*8	1
16	93110-44628	OIL SEAL 44*62*8	1
17	93320-356214	BEARING,RSDIAL BALL 6007RS	2
18	94610-10174-B	BOLT	1
19	94610-10178-B	BOLT	1
20	94710-10032-C	BOLT,STUD	8
21	94717-08028-C	BOLT,STUD	6
22	95201-081207-B	NUT,HEXAGON	2
23	95201-081406-B	NUT,HEXAGON	6
24	95201-335014-C	NUT,HEXAGON	2
25	95301-101410-B	NUT,LOCK	2
26	95326-142114-C	NUT,CASTLE FLANGE	2
27	95401-101409-C	NUT,FLANGE	8
28	96210-08055-B	BOLT,HEXAGON	2
29	97201-102620-B	WASHER,PLATE 10.3*26*2.0	4
30	97201-143240-C	WASHER,PLATE 14.2*32.5*4.0	2

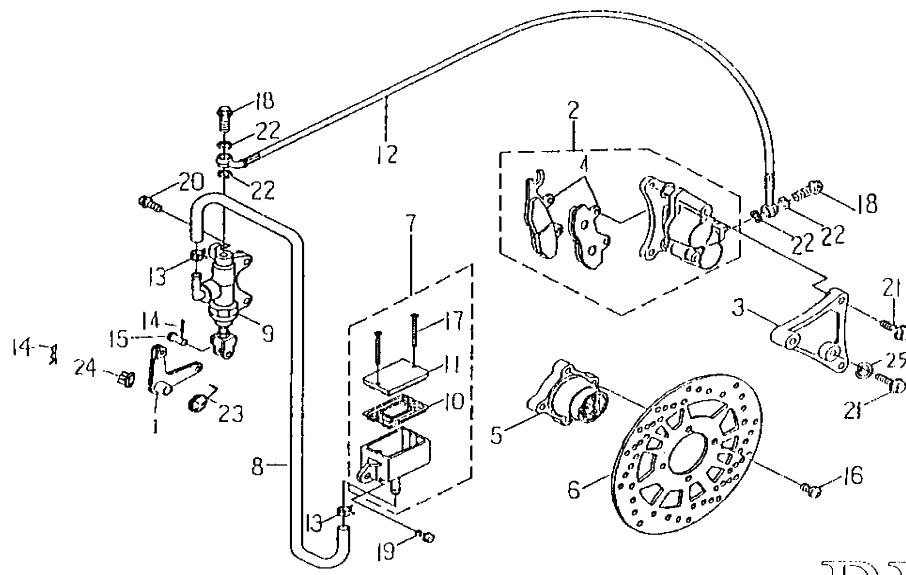

BMU  
MODEL:AAM-250E

FIG.26 REAR BRAKE 後制車系統

NO	PARTS NO.	PARTS NAME	Q'TY
1	32355-CBT-00	LEVER,CAMSHAFT	1
2	45801-RAM-00	CALIPER ASS'Y	1
3	45810-RAM-00	BRACKET,CALIPER	1
4	45815-RAM-00	PAD,CALIPER	1
5	45830-RAM-00	BRACKET,DISC	1
6	45831-RAM-00	DISC,BRAKE	1
7	45871-RAM-00	RESERVOIR	1
8	45874-RAM-00	HOSE 8*13*400	1
9	45877-RAM-00	CYLINDER KIT,MASTER	1
10	45878-NAF-00	DIAPHRAGM,RESERVOIR	1
11	45879-NAF-00	CAP,RESERVOIR	1
12	61320-RAM-00	HOSE,BRAKE	1
13	90220-80013	CLAMP	2
14	90230-12008	COTTER PIN	2
15	94610-06016-B	PIN,CLEVIS	1
16	94706-08017-B	BOLT,BUTTON	4
17	94712-04040-K	SCREW,FLAT HEAD	2
18	94716-10022-G	BOLT,UNION	2
19	96414-06016-B	BOLT,FLANGE	1
20	96414-06022-B	BOLT,FLANGE	2
21	96414-08020-B	BOLT,FLANGE	4
22	97230-101512	WASHER,COPPER 10.3*15*1.2	4
23	97508-22202-B	SPRING TORSION	1
24	95401-081208-B	NUT,FLANGE	1
25	97301-081420-B	WASHER,SPRING	2

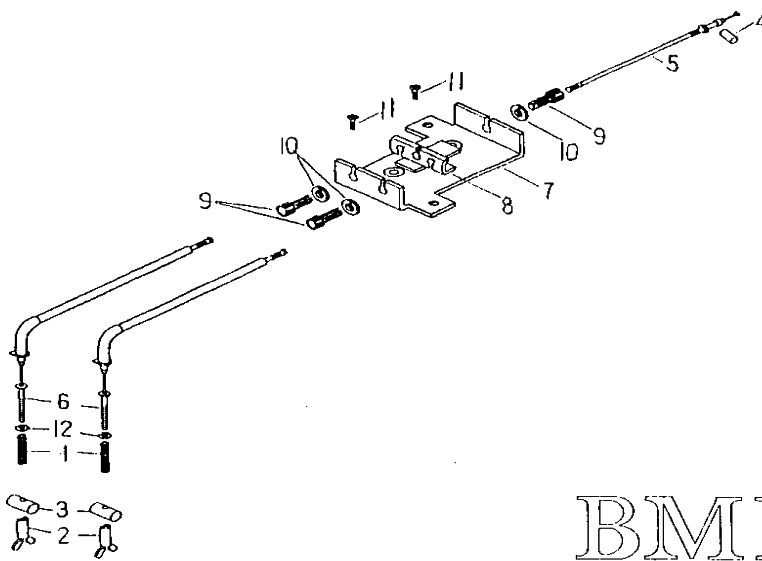
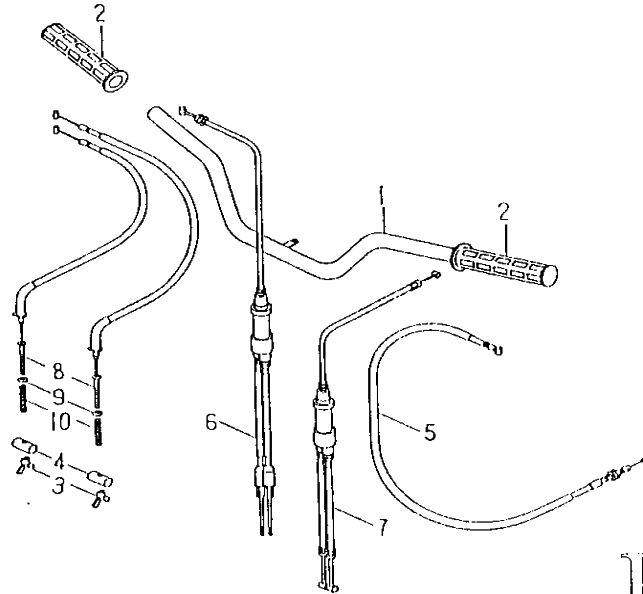

FIG.27 INTEGRATED 整合式制車系統

BMI  
MODEL : AAM-250E

NO	PARTS NO.	PARTS NAME	Q'TY
1	97501-12087-B	SPRING,COMPRESSION	2
2	61379-SK9-00	NUT,ADJUST	2
3	61389-NAF-00	PIN,FIXTURE	2
4	61389-RAM-00	PIN,FIXTURE	1
5	61811-CBT-00	CABLE,BRAKE UPPER	1
6	61812-RAM-00	CABLE,BRAKE LWR	2
7	61861-RAM-00	CABLE,PAN CONNECTOR	1
8	61863-RAM-00	SLIDER,CONNECTOR	1
9	62916-RAM-00	BOLT,WIRE ADJUSTING	3
10	62917-RAM-00	NUT,WIRE ADJUSTING	3
11	94712-05012-B	SCREW,FLAT HEAD	2
12	97011-06008-B	CIRCLIP 6*0.8	2



**BMI**  
MODEL:AAM-250E

FIG.28 STEERING HANDLE CABLE 轉向把手,鋼索

NO	PARTS NO.	PARTS NAME	Q'TY
1	46110-RAM-01	HANDLEBAR	1
2	46240-RAM-00	GRIP	2
3	61379-SK9-00	NUT,ADJUST	2
4	61389-NAF-00	PIN,FIXTURE	2
5	61420-CBT-00	CABLE,CLUTCH	1
6	61620-CBT-00	CABLE,THROTTLE	1
7	61720-CBT-00	CABLE,CHOKE	1
8	61820-RAM-00	CABLE,BRAKE	2
9	97011-06008-B	CIRCLIP 6*0.8	2
10	97501-12087-B	SPRING,COMPRESSION	2

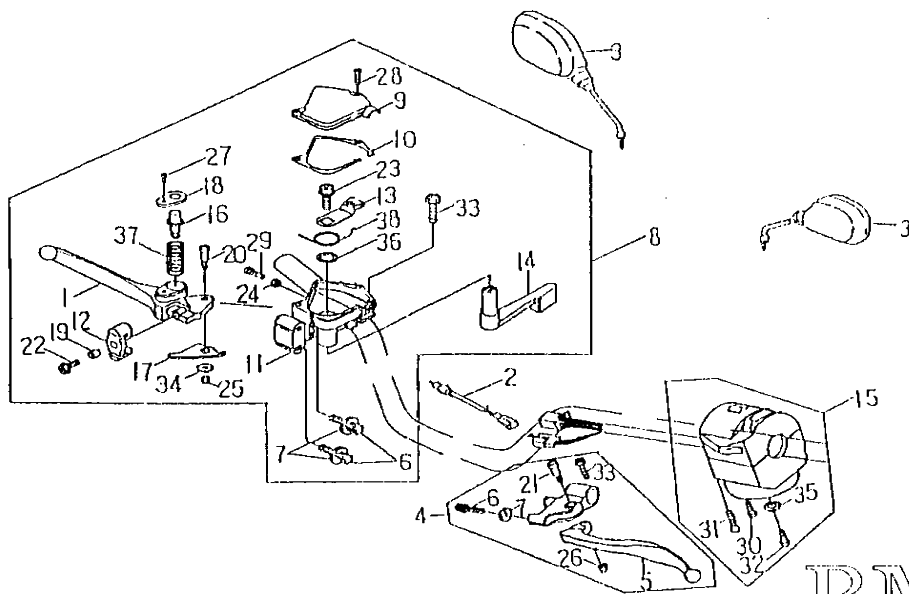

**BMI**  
MODEL:AAM-250E

FIG.29 HANDLE SWITCH , LEVER 把手開關,拉桿

NO	PARTS NO.	PARTS NAME	Q'TY
1	45872-RAM-00	LEVER,R	1
2	45890-RAM-00	WIRING,FR STOP SWITCH	1
3	56270-ROA-00	MIRROR ASS'Y,BACK	1
4	62910-RAM-01	LEVER ASS'Y,HANDLEL	1
5	62912-SK9-01	LEVER,L	1
6	62916-RAM-00	BOLT,WIRE ADJUSTING	3
7	62917-RAM-00	NUT,WIRE ADJUSTING	3
8	62920-RAM-01	THROTTLE LEVER ASS'Y	1
9	62923-RAM-00	CAP,THROTTLE	1
10	62924-RAM-00	GASKET,THROTTLE	1
11	62925-RAM-00	THROTTLE LEVER	1
12	62926-RAM-00	JOINT,CABLE	1
13	62927-RAM-00	ARM,THROTTLE	1
14	62928-RAM-00	LEVER,THROTTLE	1
15	62930-RAM-02	HANDLE SWITCH ASS'Y L	1
16	62971-RAM-00	PIN,LOCK	1
17	62973-RAM-00	LOCK,LEVER	1
18	62976-RAM-00	COVER	1
19	93560-68507	COLLAR,LEVER 6.3*8.5*7.4	1
20	94710-05022-G	BOLT,LEVER	1
21	94710-06029-G	BOLT,LEVER	1
22	94714-06016-G	BOLT	1
23	94714-08012-G	BOLT	1
24	95201-050804-G	NUT,HEXAGON	1
25	95311-050805-K	NUT,NYLON	1
26	95311-061006-K	NUT,NYLON	1
27	96310-03008-B	SCREW,PAN HEAD	1
28	96310-04015-G	SCREW,PAN HEAD	2
29	96310-05015-G	SCREW,PAN HEAD	1
30	96310-05030-G	SCREW,PAN HEAD	1
31	96310-05040-G	SCREW,PAN HEAD	1
32	96310-06010-G	SCREW,PAN HEAD	1
33	96510-06020-G	BOLT	2
34	97201-051516-C	WASHER,PLATE 5.3*15*1.6	1

35	97201-061310-B	WASHER,PLATE 6.5*13*1.0	1
36	97201-142016-C	WASHER,PLATE 14.2*19.7*1.6	1
37	97501-08025-B	SPRING	1
38	97508-10240-B	SPRING	1



BMI  
MODEL : AAM-250E

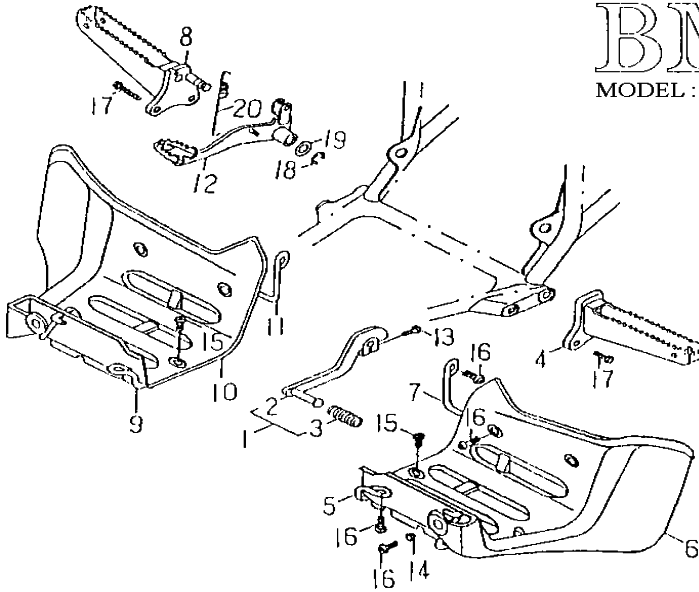
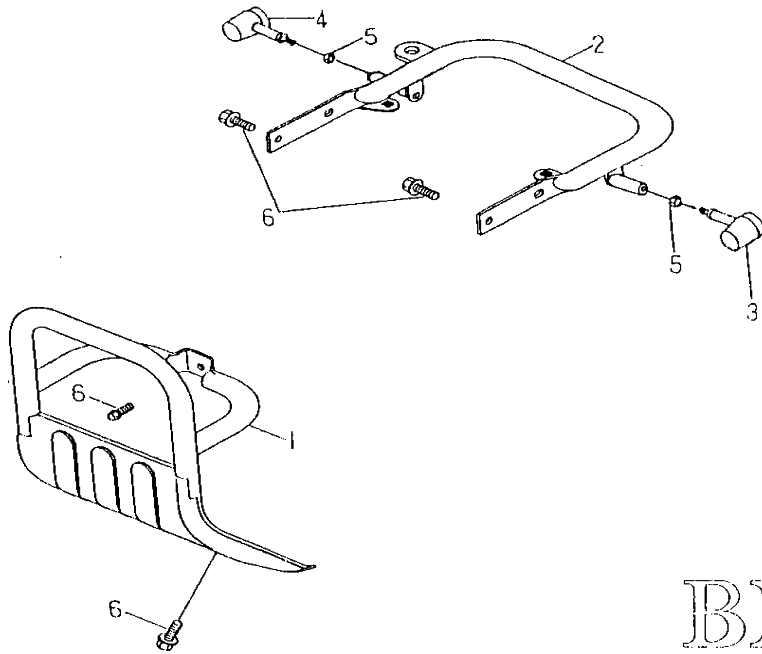

FIG.30 STAND FOOTREST 脚踏器

NO	PARTS NO.	PARTS NAME	Q'TY
1	53210-RAM-00	CHANGER PENDAL ASS'Y	1
2	53211-RAM-00	CHANGER PENDAL	1
3	53214-ROA-00	RUBBER,CHANGE PEDAL	1
4	53231-RAM-00	FOOTREST L	1
5	53233-RAM-00	MUDGUARD STAY L1	1
6	53234-RAM-00	MUDGUARD L	1
7	53236-RAM-00	MUDGUARD STAY L2	1
8	53241-RAM-02	FOOTREST R	1
9	53243-RAM-00	MUDGUARD STAY R1	1
10	53244-RAM-00	MUDGUARD R	1
11	53246-CBT-00	MUDGUARD STAY R2	1
12	53261-CBT-01	PEDAL,BRAKE	1
13	94714-06020-B	BOLT,FLANGE	1
14	95401-061006-B	NUT,FLANGE	1
15	96318-06012-B	SCREW,PAN HEAD	6
16	96318-06015-B	SCREW,PAN HEAD	8
17	96414-10025-B	BOLT,FLANGE	4
18	97011-12010-B	CIRCLIP 12*1.0	1
19	97201-152620-B	WASHER,PLATE 15.2*25.6*2.0	1
20	97506-12140-B	SPRING,TENSION	1



**BMI**  
MODEL:AAM-250E

FIG.31 GUARD 保護桿

NO	PARTS NO.	PARTS NAME	Q'TY
1	41601-RAM-00	SHIELD,FRONT	1
2	42850-RAM-04	SHIELD,REAR	1
3	55750-RAM-00	WINKER ASS'Y,L REAR	1
4	55760-RAM-00	WINKER ASS'Y,R REAR	1
5	95201-101408-B	NUT,HEXAGON	2
6	96414-08016-B	BOLT,FLANGE	7

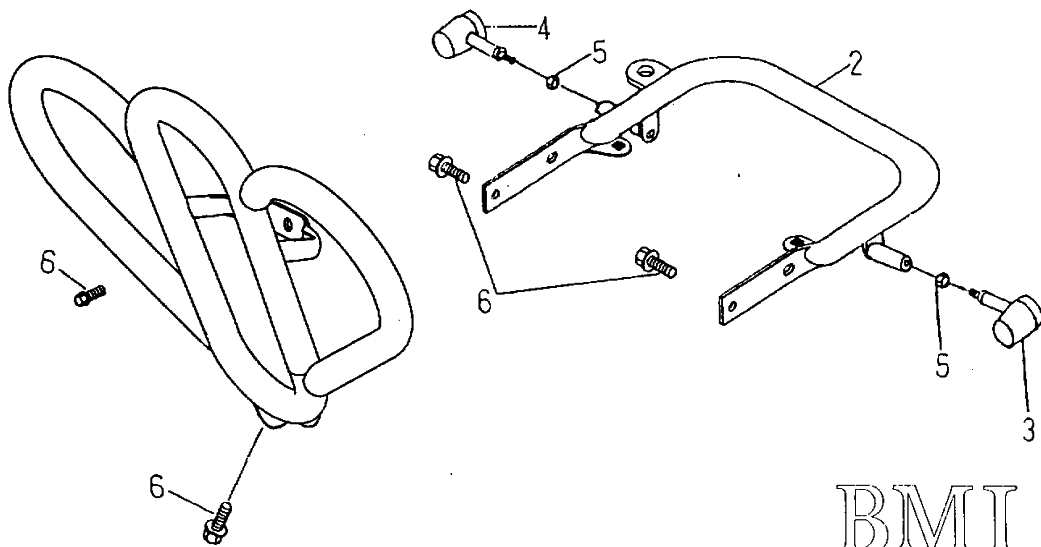
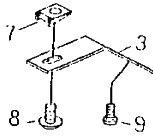
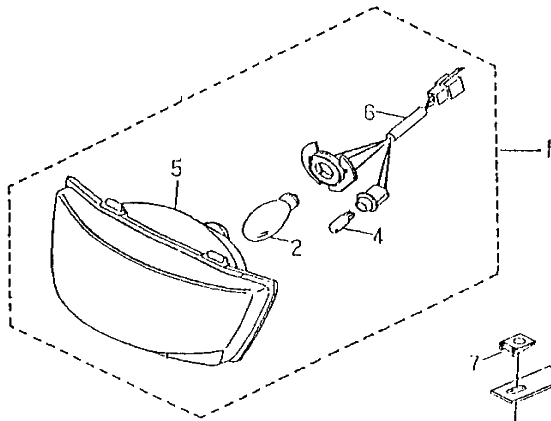

FIG.31 GUARD 保護桿 (FOR OIL COOLER)

BMI  
MODEL : AAM-250E

NO	PARTS NO.	PARTS NAME	Q'TY
1	41601-QUA-01	SHIELD,FRONT(FOR OIL COOLER)	1
2	52850-RAM-04	SHIELD,REAR	1
3	55750-RAM-00	WINKER ASS'Y,L REAR	1
4	55760-RAM-00	WINKER ASS'Y,R REAR	1
5	95201-101408-B	NUT,HEXAGON	2
6	96414-08016-B	BOLT,FLANGE	7



**BMI**  
MODEL: AAM-250E

FIG.32 HEADLIGHT 前燈

NO	PARTS NO.	PARTS NAME	Q'TY
1	55300-STG-00	HEAD LIGHT ASS'Y	1
2	55314-NFF-00	BULB,HEAD LIGHT 12V 35/35W	1
3	55315-STG-00	STAY,HEAD LIGHT	1
4	55316-NGF-00	BULB,POSITION LAMP	1
5	55320-STG-00	LENS ASS'Y	1
6	55340-STG-00	SOCKET CORD ASS'Y	1
7	95101-05012	NUT,SPRING	1
8	96112-51616-K	SCREW,TAPPING	1
9	96310-04010-B	SCREW,PAN HEAD	1

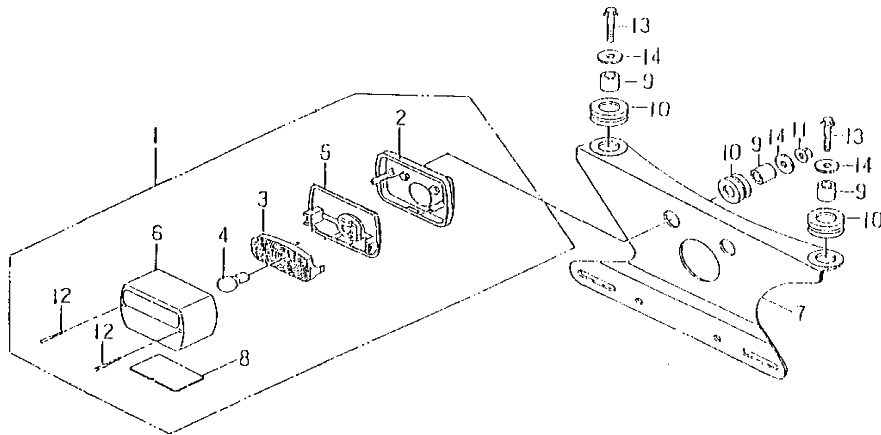

FIG.33 TAIL LIGHT 後燈

BMI  
MODEL:AAM-250E

NO	PARTS NO.	PARTS NAME	Q'TY
1	55700-CHP-00	TAIL LIGHT ASS'Y	1
2	55701-CHP-00	STAND, TAIL LIGHT	1
3	55713-PAF-00	BULB STAND, TAIL LIGHT	1
4	55714-PAF-00	BULB, TAIL LIGHT	1
5	55715-PAF-00	WASHER	1
6	55721-PAF-00	LENS, TAIL LIGHT	1
7	55726-RAM-00	HOLDER, TAIL LIGHT	1
8	55743-PAF-00	LENS, LICENSE LIGHT	1
9	93510-061010	COLLAR	4
10	93580-102212	GROMMET	4
11	95401-061006-B	NUT, FLANGE	2
12	96112-43818-B	SCREW, TAPPING	2
13	96414-06020-B	BOLT, FLANGE	2
14	97201-061820-B	WASHER, PLATE	4

**BMI**  
MODEL : AAM-250E

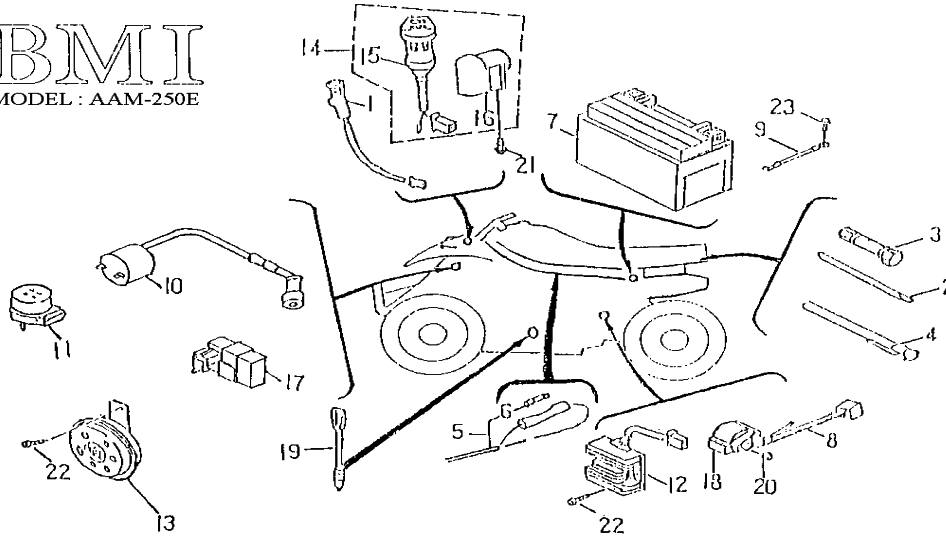

FIG.34 WIRE HARNESS 主電路配線

NO	PARTS NO.	PARTS NAME	Q'TY
1	55550-RAM-00	NEUTRAL LIGHT ASS'Y	1
2	56120-CBT-00	SCREW DRIVER	1
3	56140-CBT-00	TOOL PLUG	1
4	56190-RAM-00	GAUGE,AIR	1
5	61120-CBT-02	WIRE,HARNESS	1
6	61151-CHP-00	FUSE (15A250V)	1
7	62100-CHP-00	BATTERY ASS'Y (YTX9A-BS)	1
8	62110-CBT-00	CABLE,BATTERY	1
9	62120-RAM-00	CABLE,EARTH	1
10	62310-CBT-00	IGNITION COIL ASS'Y	2
11	62350-NAF-01	FLASHER RELAY ASSEMBLY	1
12	62360-CBT-00	RECTIFIER&REGULATOR COMP	1
13	62370-NAF-00	HORN	1
14	62500-RAM-00	KEY SET	1
15	62501-RAM-00	MAIN SWITCH ASS'Y	1
16	62503-RAM-00	LOCK COMP,STEERING HANDLE	1
17	62540-CBT-00	C.D.I UNIT ASS'Y	1
18	62550-CBT-00	STARTER RELAY SWITCH COMP	1
19	62980-CHP-00	SWITCH ASS'Y,REAR STOP	1
20	95401-061006-B	NUT,FLANGE	1
21	96310-05012-B	SCREW,PAN HEAD5*12	2
22	96312-06016-K	SCREW,PAN HEAD WITH WASHER	2
23	96414-06012-B	BOLT,FLANGE	1

BMI  
MODEL : AAM-250E

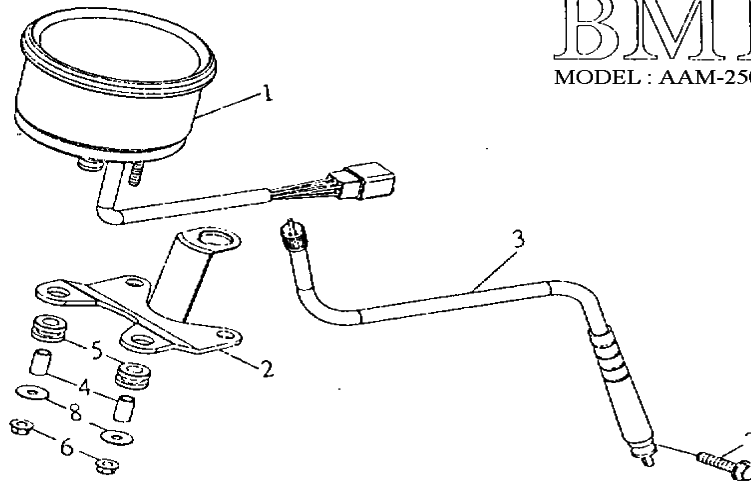
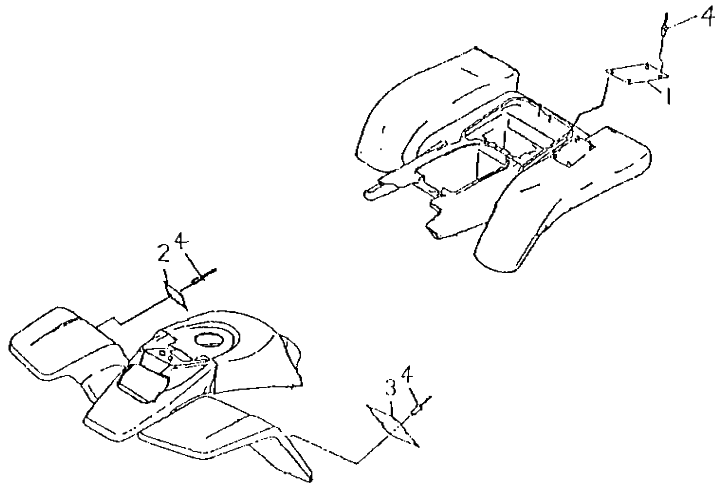

FIG.35 SPEEDOMETER 速度表

NO	PARTS NO.	PARTS NAME	Q'TY
1	55510-RAM-01	SPEEDOMETER ASS'Y	1
2	55516-RAM-01	HOLDER,SPEEDOMETER	1
3	61520-RAM-01	CABLE,SPEEDOMETER ASS'Y	1
4	93510-050814-B	COLLAR,SPEEDOMTER	2
5	93580-81615	GROMMET	2
6	95401-050805-B	NUT,FLANGE	2
7	96414-06020-B	BOLT,FLANGE 6*20	1
8	97201-051610	WASHER,PLATE 5.3*16*1	2



BMI  
MODEL:AAM-250E

FIG.36 警告標示

NO	PARTS NO.	PARTS NAME	Q'TY
1	56576-AAM-01	LABEL WARNING 3 (Tire)	1
2	56578-AAM-00E	LABEL WARNING 2 (Age)	1
3	56781-AAM-01	LABEL WARNING 1 (Operation)	1
4	94320-32096	RIVET 3.2*9.6	14



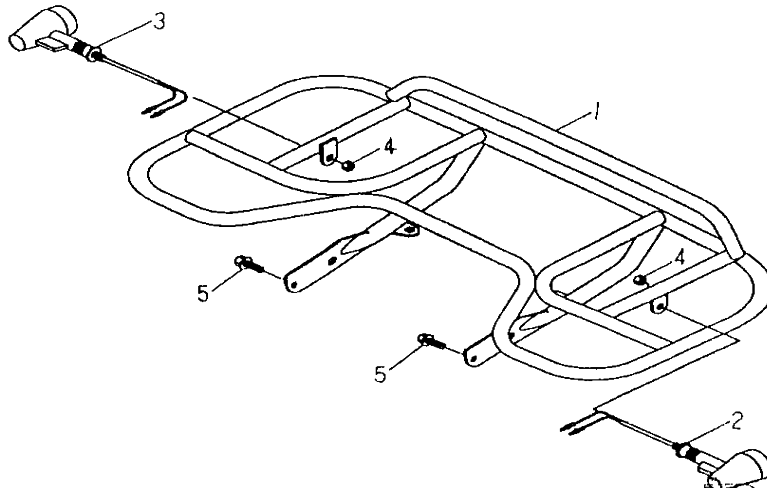

**BMI**  
MODEL:AAM-250E

FIG.37 CARRIER,REAR 後架

NO	PARTS NO.	PARTS NAME	Q'TY
1	52850-RAM-03	CARRIER,FRONT	1
2	55750-RAM-00	WINKER ASS'Y,L REAR	1
3	55760-RAM-00	WINKER ASS'Y,R REAR	1
4	95201-101408-B	NUT,HEXAGON	2
5	96414-08016-B	BOLT,FLANGE	4

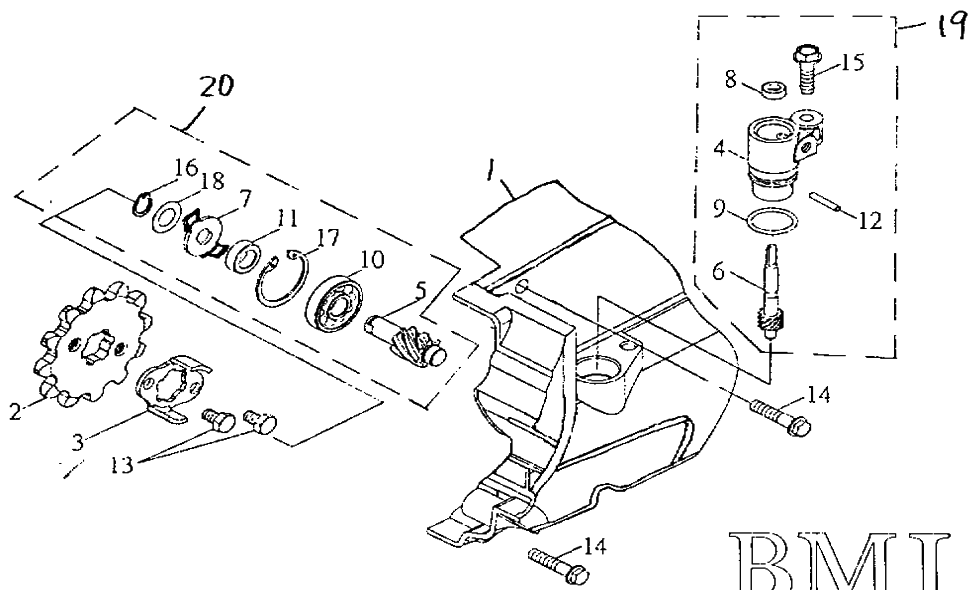
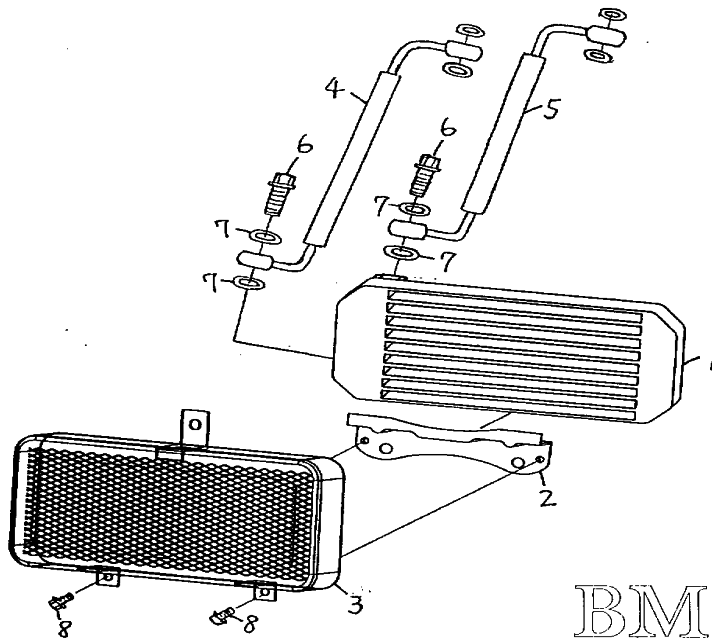

FIG.38 GEAR,SPEEDOMETER 速度表齒輪

BMI  
MODEL : AAM-250E

NO	PARTS NO.	PARTS NAME	Q'TY
1	15421-CBT-01	COVER,L REAR CRANKCASE	1
2	25711-RAM-00	SPROCKET DRIVE(12T)	1
3	25716-RAM-00	PLATE, FIXING	1
4	42563-GOO-00	GEAR,SPEEDOMETER BODY	1
5	45835-CBT-00	GEAR DRIVE (8T)	1
6	45838-RAM-00	GEAR,SPEEDOMETER (10T)	1
7	45849-CBT-00	CLUTCH SPEEDOMETER	1
8	93110-06114	OIL SEAL VC 6*11*4	1
9	93210-15190	O-RING 1.5*19	1
10	93320-103009U	BEARING,RADIAL BALL 6200LUCS05/2A	1
11	93510-101706-B	COLLAR	1
12	94510-30018	PIN,DOWEL 3*18	1
13	96210-06010-B	BOLT,HEXAGON 6*10	2
14	96411-06020-B	BOLT,FLANGE 6*20	2
15	96414-06025-B	BOLT,FLANGE 6*25	1
16	97010-10010-K	CIRCLIP STW-10	1
17	97012-30012-K	CIRCLIP RTW-30	1
18	97201-101805	WASHER,PLATE 10.5*18*0.5	1
19	42560-AAM-00	GEAR,SPEEDOMETER ASS'Y	1
20	45834-CBT-00	GEAR DRIVE ASS'Y	1



**BMI**  
MODEL : AAM-250E

FIG.39 OIL COOLING SET 機油冷卻裝置

NO	PARTS NO.	PARTS NAME	Q'TY
1	61900-CBT-00	OIL COOLING TANK	1
2	61903-CBT-00	LWR HOLDER,OIL COOLING TANK	1
3	61904-CBT-00	OIL COOLING TANK COVER	1
4	61910-CBT-00	TUBE,OIL COOLING TANK (405MM)	1
5	61911-CBT-00	TUBE,OIL COOLING TANK (420MM)	1
6	94716-12032-G	BOLT,UNION M12*32L	2
7	97231-122020	WASHER,ALUMINUM 12.3*20*2.0	8
8	96414-06012-B	BOLT,FLANGE 6*12	2